

07

# METAL SHEATHED RESISTANCE THERMOMETERS

- Probe sheaths are available in a wide range of steel grades to suit various operating environments.
- Depending of sensor type and a certain construction, RTD can work even up to 850 °C.
- With the appropriate probe sheath the sensor is suitable for oxidising, reducing, neutral and full sour gases atmosphere.
- Can be produced with the changeable insert
- The sensors can be calibrated in the Accredited Laboratory

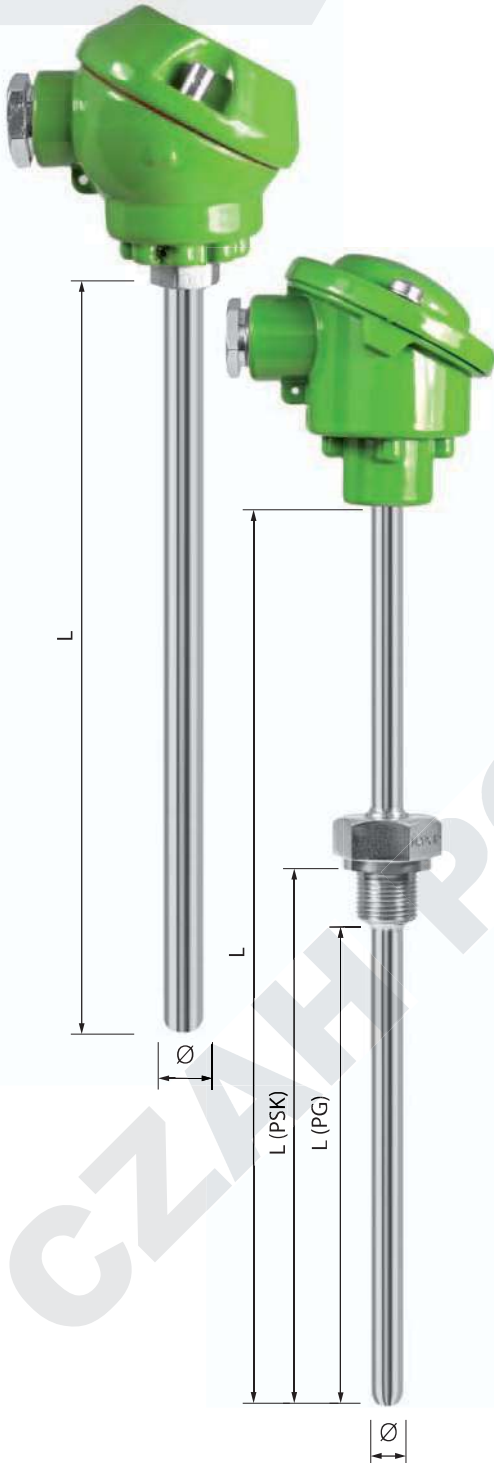

07	measuring element type	accuracy class	wiring configuration	sheath material	sheath diameter	length	head type	measuring insert type	fixing	head transmitter	max. operating temperature
Pt100, 2xPt100, Pt500, 2xPt500, Pt1000, 2xPt1000											
Give accuracy class, table 1		Give wiring configuration, table 2		Give sheath type, table 3		Give sheath diameter, table 4		Give length L [mm]		Give head type, table 5	
Give insert type W: changeable version:; S: not moveable ( possibility of moveable insert application depends on the sensor diameter)		Give a type of additional assembling parts, see table 6. For a thread, please specify its dimensions [mm] from sensor tip to a thread L (PG) or to a hexagon L (PSK). For a flange DN20, please specify L (DN) (skip if not requested)		Give temperature transmitter details, see table 7 (skip if not requested)		Give max. operating temperature for the sensor tip					

## TAB. ORDERING CODE:

07	Pt 100	A	4	321	10	345	B	W	G12 200(PSK)	-	250 °C
----	--------	---	---	-----	----	-----	---	---	-----------------	---	--------

### 07 – Pt100 – A – 4 – 321 – 10 – 345 – B – W – G12 200(PSK) – 250 °C

Temperatur sensor type 07 (resistance thermometer, metal sheathed), type Pt100, class A, 4-wire version, thermowell material: steel 321 (1H18N9T), thermowell diameter 10 mm, total length L=345 mm, length beneath the hex fitting L (PSK)= 200 mm. Sensor with the head type B, the changeable measuring insert, welded fitting with thread G12. Max. operating temperature is 250 °C

**TAB. 1 TRANSMITTER TOLERANCE CLASS AND OPERATING TEMPERATURES \*)**

TOLERANCE CLASS	FOR WIRE WOUND RESISTORS	FOR THIN FILM RESISTORS	TOLERANCE VALUE **)
<b>AA</b>	-50 ÷ +250	0 ÷ +150	± (0.1+0.0017 t )
<b>A</b>	-100 ÷ +450	-30 ÷ +300	± (0.15+0.002 t )
<b>B</b>	-196 ÷ +660	-50 ÷ +500	± (0.3+0.005 t )
<b>C</b>	-196 ÷ +660	-50 ÷ +600	± (0.6+0.01 t )

\*) to PN-EN60751:2009

\*\*) |t| = temperature in °C no matter what unit (absolute value)

**TAB. 2 WIRING CONFIGURATION AND COLOUR MARKING**

SINGLE (ONE RESISTOR)		
2-WIRE DESIGN	3-WIRE DESIGN	4-WIRE DESIGN
<p>A rectangular resistor with two wires extending from its top. The top wire is labeled 'red' and the bottom wire is labeled 'white'.</p>	<p>A rectangular resistor with three wires extending from its top. The top two wires are labeled 'red' and the bottom wire is labeled 'white'.</p>	<p>A rectangular resistor with four wires extending from its top. The top two wires are labeled 'red' and the bottom two wires are labeled 'white'.</p>
DOUBLE (2 RESISTORS)		
2-WIRE DESIGN	3-WIRE DESIGN	4-WIRE DESIGN
<p>Two rectangular resistors are shown stacked vertically. The top resistor has two wires: 'red' (top) and 'white' (bottom). The bottom resistor has two wires: 'black' (top) and 'yellow' (bottom).</p>	<p>Two rectangular resistors are shown stacked vertically. The top resistor has three wires: two 'red' wires (top) and one 'white' wire (bottom). The bottom resistor has three wires: two 'yellow' wires (top) and one 'black' wire (bottom).</p>	<p>Two rectangular resistors are shown stacked vertically. The top resistor has four wires: two 'red' wires (top) and two 'white' wires (bottom). The bottom resistor has four wires: two 'yellow' wires (top) and two 'black' wires (bottom).</p>

**TAB. 3 STEEL SHEATH MATERIAL \*)**

TYPE	DESCRIPTION
<b>INC</b> (Inconel 600; 2.4816)	Nickel-chrome-iron alloy characterized by great resistance to oxidising and high temperature
<b>310</b> (H25N20S2; 1.4841)	Steel containing 25%Cr – 20%Ni. It is stainless and heat resistant
<b>304</b> (1.4301; 0H18N9)	Austenitic stainless steel 18%Cr-8%Ni. Corrosion resistant (with no excess oxidation and no resistance lost) up to 800 °C. It is the most popular acidproof material, easy for metalworking and welding
<b>321</b> (1.4541; 1H18N9T)	Steel similar to grade 304 (18% Cr, 10% Ni) but with titanium as a stabilizer.
<b>316</b> (1.4401; H17N13M2T)	Steel similar to 304 (17% Cr, 9% Ni) with 3% of molybdenum. Because this steel grade is more corrosion resistant than 321 and 304, it is good for humid environment and for applications in places threatened by corrosion (sea water).







\*) other steel types available on request

**TAB. 4 DIAMETER**

OUTER THERMOWELL DIAMETER [mm] *)
4,0
5,0
6,0
8,0
10,0
12,0
15,0

\*) other diameters available on request

**TAB. 5 TERMINAL HEAD TYPES**

TYPE	TERMINAL HEAD *) **)		
	B	NA	MA ***)
			
TYPE	DA	G1	G2
			

\*) other heads available on request

\*\*) for technical data see table A, page 50

\*\*\*) MA head possible only for thermowells with max. diameter 12 mm.

**TAB. 6 FIXING**

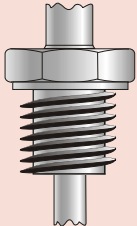
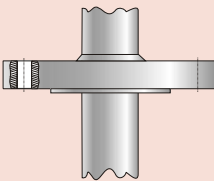
CODE	DESCRIPTION	MATERIAL	THREAD	DRAWING **)
<b>M2015</b>			M20x1.5	
<b>G12</b>	Fitting welded to the thermowell *)	steel	G1/2"	
<b>G10</b>			G1.0"	
<b>G34</b>			G3/4"	
<b>UZ 22</b>	Mounting bracket D=22 mm **)		Aluminium+ steel alloy	n/d
<b>UZ25</b>	Mounting bracket D=25 mm **)			
<b>DN20</b>	Flange welded to the thermowell **)	steel	n/d	

\*) other threads on request \*\*) see table G, page 62 for more information

**TAB. 7 TEMPERATURE TRANSMITTER**

If the in-head signal transmitter is requested eg. signal 4...20 mA, please give all the necessary details, such as: type, temperature range. List of transmitters is available in the table E, page 60.